

NORBIT - iWBMSH HIGH-END TURNKEY MULTIBEAM SONAR SYSTEM

For High Resolution Bathymetric Survey In All Conditions

Introducing the first, go-anywhere, go-anytime ultra-high resolution curved-array bathymetric mapping solution featuring industry leading GNSS/INS positioning system from NORBIT.

This most compact, highest resolution, tightly integrated, broadband multibeam sonar solution offering a curved array and GNSS/INS that is suited for the most demanding environments (Applanix OceanMaster). The iWBMSH is ready for rapid mobilization and delivers highest XYZ performance for the price.

The iWBMSH is fully integrated with highest performing sensors to work in the most challenging environments (under bridges or in rough sea conditions). Small form factor, low power draw and tight integration allows installation on any survey platform (permanent hull mount or pole mount). Hands-free system tuning ensures quality data on the first survey. The WBMS sonars are based on a state of the art analog and digital platform featuring powerful signal processing capabilities, offering roll stabilized bathymetry and several imagery and backscatter output. With broad R&D expertise NORBIT has developed, from the ground-up, exciting new technology that allows existing and new applications to benefit from the advantages offered by a compact wideband curved-array multibeam sonar.



Features

- ✓ Multibeam Sonar tightly Integrated with State of the Art GNSS-aided Inertial Navigation System (Applanix OceanMaster)
- ✓ 80kHz Bandwidth
- ✓ Roll-stabilisation, Side-scan, Water Column, Backscatter, Snippets
- ✓ Simple Ethernet Interface
- ✓ Integrated Sound Velocity Probe
- ✓ Hydrodynamic Fairing
- ✓ Mounting Bracket Included
- ✓ FM & CW Processing
- ✓ Flexible Power Option
- ✓ Exceeds IHO *Special Order*, CHS *Exclusive Order* & USACE *New Work*

Applications

- ✓ Coastal Zone and Offshore Bathymetry
- ✓ Pipeline Surveys
- ✓ Pond, River and Estuary Surveys
- ✓ Harbor and Lake Surveys
- ✓ USV & UUV Ready
- ✓ MCM & Littoral Combat Zone Surveys

Options

- ✓ Senior Hydrographer for Support and Training
- ✓ Sound Velocity Profiler
- ✓ Laptop
- ✓ Turnkey Survey Solutions
- ✓ Permanent Hull Mount Option
- ✓ Pole Mount and Travel Option
- ✓ Narrow Beam Option
- ✓ Acquisition, Navigation and Post Processing Software
- ✓ Can be Delivered with all Major Software Packages e.g. HYPACK, QINSy, EIVA, CARIS and Others

EXPERTS in sensor equipment providing telemetry and communication solutions for harsh environments. NORBIT develops and delivers innovative products - allowing you to explore more.

NORBIT High-End Turnkey Multibeam Sonar System For High Resolution Bathymetric Survey In All Conditions

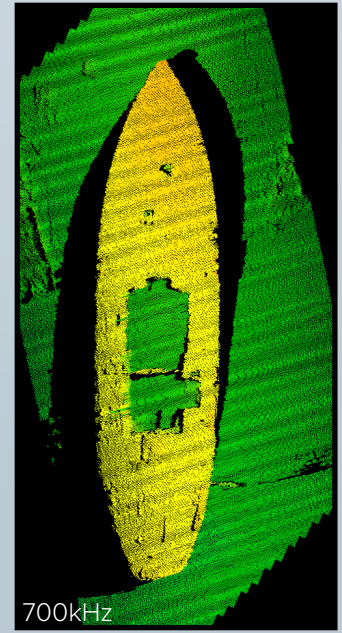
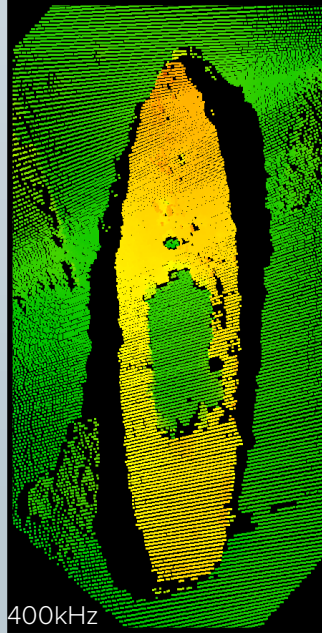
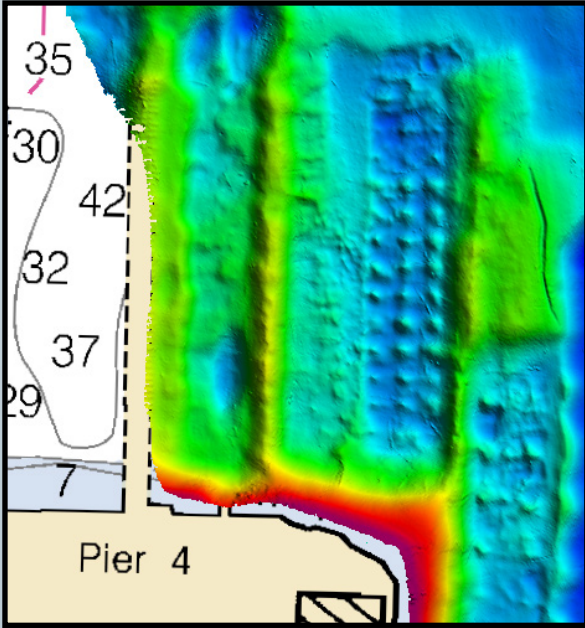
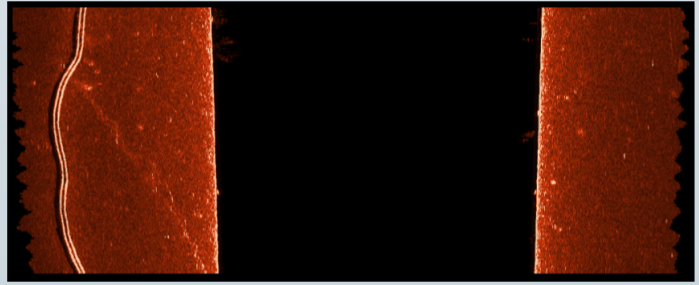
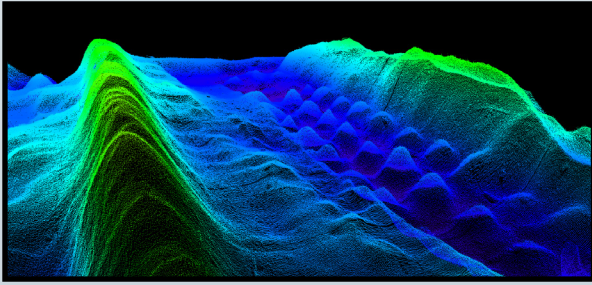

TECHNICAL SPECIFICATION

SWATH COVERAGE	7-210° FLEXIBLE SECTOR (SHALLOW WATER IHO SPECIAL ORDER >155°)
RANGE RESOLUTION	<10mm ACOUSTIC W. 80kHz BANDWIDTH
NUMBER OF BEAMS	256-512 EA & ED
OPERATING FREQUENCY	NOMINAL FREQUENCY 400kHz (FREQUENCY AGILITY 200-700kHz)
DEPTH RANGE	0.2-275m (160m TYPICAL)
PING RATE	UP TO 60Hz, ADAPTIVE
RESOLUTION (ACROSS X ALONG)	STANDARD: 0.9° X 1.9° @400kHz AND 0.5° X 1.0° @700kHz. NARROW OPTION: 0.9° X 0.9° @400kHz AND 0.5° X 0.5° @700kHz
POSITION	HOR: ±(8mm +1ppm X DISTANCE FROM RTK STATION) VER: ±(15mm +1ppm X DISTANCE FROM RTK STATION) (ASSUMES 1m GNSS SEPARATION)
HEADING ACCURACY	0.02° (RTK) WITH 2m ANTENNA SEPARATION
PITCH/ROLL ACCURACY	0.01° INDEPENDENT OF ANTENNA SEPARATION
HEAVE ACCURACY	5cm or 5% (2.5cm or 2% TrueHeave)
WEIGHT	APPROX. 9.2kg (AIR) LESS THAN 6kg (WATER)
INTERFACE	ETHERNET
CABLE LENGTH	STD 8m, OPTIONS: 25m, PIGTAIL, CUSTOM UP TO 50m
POWER CONSUMPTION	60W (75W MAX) (10-28VDC, 110-240VAC)
OPERATING TEMP.	-4°C to +40°C (TOPSIDE -20°C to +55°C)
STORAGE TEMP.	-20°C TO +60°C
ENVIRONMENTAL	TOPSIDE: IP67: DUST TIGHT, PROTECTED AGAINST THE EFFECT OF IMMERSION UP TO 1m/WET-END: 100m

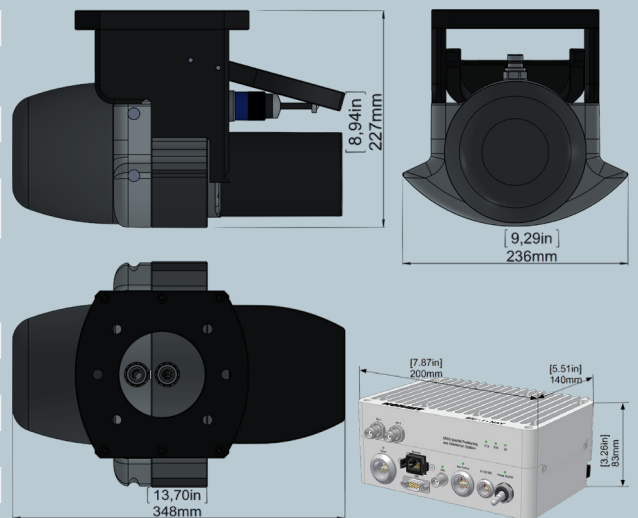

Part #12007